

Ventilation Breath Modes

- PCV** Pressure Control Ventilation (Default mode)
- PCV + PSV** SIMV (Synchronized Intermittent Mandatory Ventilation)
- PSV** Pressure Support Ventilation (Spontaneous)

Patient Settings

- P/P_{SUPP}** Inspiratory Pressure Setting (cmH₂O), (PCV)
Pressure Support Setting (cmH₂O), (PSV)
- f** Respiratory Rate (BPM), (PCV)
- T_i** Inspiratory Time (Sec), (PCV)
- E_{SENS}** Exhalation Sensitivity (%), (PSV)

Common Settings

- V_{SENS}** Trigger Sensitivity (L/min or Unitless for NIV)
- O₂%** Inspired Oxygen Percent (FiO₂)
(Set Externally by Oxygen Flow Rate)
- PEEP** Positive End Expiratory Pressure (cmH₂O)
- ALARM LIMITS** Adjustable Alarm Limits
(High/Low Exhaled TV, Disconnect, High Respiratory Rate, Apnea, High/Low Pressure, High/Low PEEP)

Alarms

- AUDIO PAUSED** Alarm Pause (Press once for two minute pause)
- ALARM** Alarm Priority & System Status LEDs
(Red – High; Yellow – Medium; Green – Normal)
- ALARM RESET** Alarm Reset (Hold for two Seconds to reset)

User Interface

- CANCEL** Cancel Setting Adjustment or Return to Main Screen
- SEL** Confirm Setting or Breath Mode
- + / -** Adjust Setting Values Up and Down
- ← / →** Scroll Between Displays and Setting Screens

Suctioning the Patient

Suctioning is required to remove mucus from the patient lungs during mechanical ventilation. This is associated with risk of false triggers and/or erroneous false technical faults, such as a Disconnect alarm being annunciated.

Breath delivery will continue during suctioning.

In order to begin suction, set the O₂% to 100% for a few minutes before initiating suctioning, if in the medical opinion of the physician this is necessary. Any Ventilation modes and settings can be used for closed suctioning.

Setting and Delivering Oxygen

Utilizing the O₂% button, set the desired FiO₂, and the system will calculate the required Oxygen flow rate. This O₂ flow rate will need to be set externally by the user. The Minute Ventilation is displayed to the user to aid in this setting.

An alarm will NOT sound on the Ventilator if there is an interruption to the O₂ supply. If the supply is interrupted, it could result in the FiO₂ being lower than the amount set on the unit (down to 21%). Appropriate patient monitoring should be used, as medically indicated, such as an alarming pulse oximeter and the required external alarming Oxygen monitor.

RESPOND 19 Ventilator Setup

An external monitor must be used to verify Oxygen accuracy and must be used to finely adjust the input flow rate for the targeted O₂%. This monitor will also indicate a loss of gas supply via the low oxygen alarm target that is user set.

Set the monitor's Oxygen High and Low alarms to 5-10% above and below the intended oxygen percent target to indicate that the gas supply is not properly delivering flow or has lost supply.

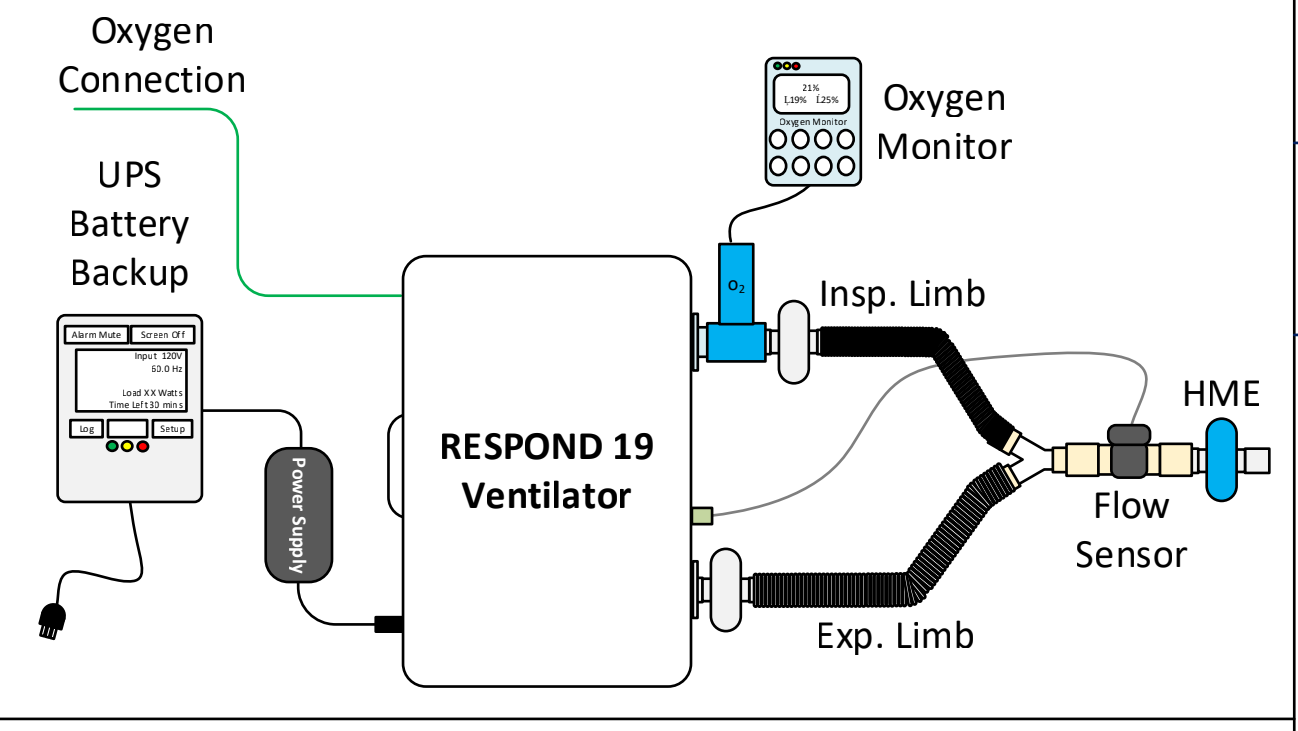

Personnel must become thoroughly familiar with the Operators Manual prior to using the RESPOND 19 Ventilator on a patient.

Changing Breath Modes

PCV to SIMV: PSV → SEL → SEL

SIMV to PSV: PCV or PSV → - → SEL

PSV to SIMV: PCV → SEL → SEL

SIMV to PCV: PSV or PCV → + → SEL

Breath Types and Running SST in Standby Mode

Changing Between Invasive and Non-Invasive (NIV): V_{SENS} → + → SEL

The center ventilation mode LED will illuminate green when in NIV

Run Short-Self Test (SST): ALARM LIMITS → SEL

SST Troubleshooting Information (* will align next to failed parameter):

- **C (Compliance)** may mean an incorrect patient circuit is used
- **Leak** may mean a disconnect is present
- **Ri (Inspiratory Resistance)** may mean Insp. Filter is missing or occluded
- **Re (Expiratory Resistance)** may mean Exp. Filter is missing or occluded
- **Rhme (HME Resistance)** may mean HME is missing or occluded

Ensure that the Patient is NOT connected to the Ventilator when changing Ventilation Types and is NOT connected when running SST. These functions can ONLY be performed in STANDBY MODE.

RESPOND 19 Ventilator Troubleshooting

LCD Screen Blank, displaying Solid White Boxes, or Display Erratic	Momentarily press the Run/Standby button quickly. This will reset the LCD and Membrane Panel User Interface.
Membrane Panel User Interface Not Responsive	Power cycle unit to reset system if problem persists.
Disconnect or Flow Sensor Not Connected Alarm that will not clear	Check all Patient Circuit connections and sampling ports. Adjust Disconnect alarm limit if needed. Replace Flow Sensor Cable. Replace Flow Sensor.
Nothing happens when device is plugged in and power is turned on	Check power cable connection to the system at wall outlet (red plug) and into universal power supply. Check to ensure that power cable is locked into rear of Ventilator. Try different power supply.
POST or BIOT Failure	Ensure switch on rear of unit is turned to 'On' state when attempting to run ventilator. Power cycle unit to reset system if problem persists.

Refer to IFU112 – RESPOND 19 Operators Manual for complete list of Features and Warnings